



# e-MCM

Motor Condition Monitoring Without Sensors

# A New Approach in Predictive Maintenance

## e-MCM

The Artesis e-MCM is a powerful online condition monitoring, predictive maintenance and power meter tool intended for critical AC rotating equipment. The patented machine learning algorithm of e-MCM enables comprehensive fault detection up to 6 months in advance. With around the clock monitoring and real-time model-based voltage and current analysis, e-MCM can detect electrical, mechanical as well as process faults of fixed, variable speed motors and generators while providing all the benefits without the high complication and cost of traditional systems.

Artesis e-MCM monitors the condition of equipment driven by an electric motor, effectively using the motor itself as a sophisticated transducer. It requires only connection into the motor's electrical supply, avoiding the need for specialised sensors. Because Artesis e-MCM is permanently installed, it provides continuous fault monitoring and does not depend on expensive manual data collection.



# Artesis Condition Monitoring System

## e-MCM

The patented NASA-developed technology provides machine learning capability in a compact, affordable, panel-mounted instrument. e-MCM can detect wide variety of faults by automatically teaching itself about the normal operation environment of your equipment so that it can accurately identify and diagnose faults long before they become a threat.

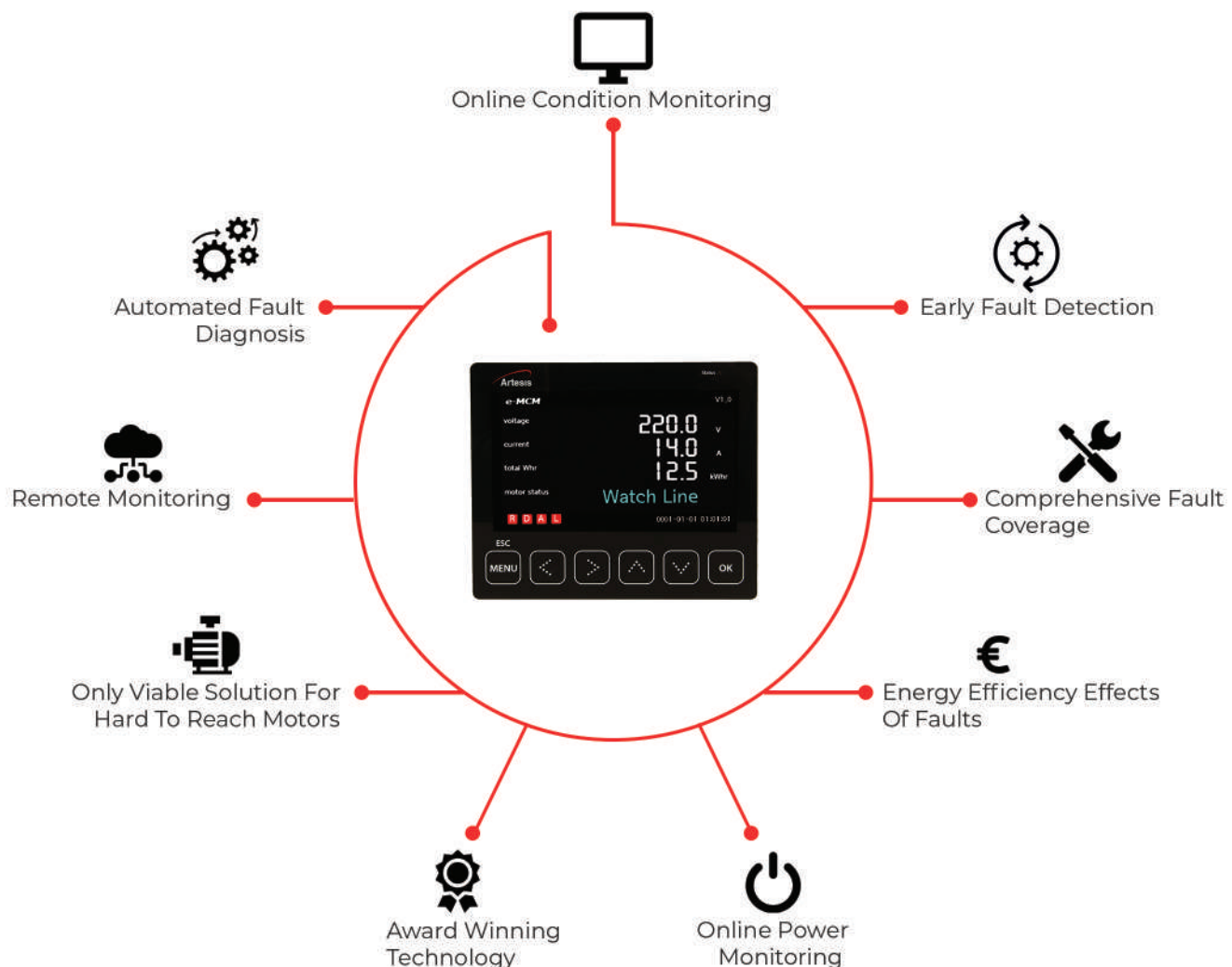



### **Key Benefits**

- Decrease on maintenance cost
- Productivity increase
- Equipment life extension
- Energy saving
- Improved process safety

### **Sectors**

- Oil & Gas
- Energy
- Cement
- Metal
- Pharmaceutical
- Automotive
- Water
- Transportation
- Food & Beverages
- Buildings

### **Applications**

- Compressors
- Fans
- Pumps
- Conveyors
- Generators
- Motor Driven Equipment
- AHU
- Mixer



Watch e-MCM video

# Continuous Monitoring of Your Rotating Equipment

e-MCM monitors your rotating equipment continuously, constantly taking measurements and comparing them with the digital twin it created during the self-learning process. Unlike conventional online systems, its unique machine learning algorithm allows it to recognise normal operation in a wide range of conditions, such as different speeds or loads – allowing tight control without false alarms. If e-MCM identifies a new operating state not experienced during the self-learning phase, it gives you the option of including this state in all future monitoring.



## Fault Coverage

- Loose foundation/components
- Mechanical unbalance/missalignment
- Transmission faults
- Driven equipment faults
- Gearbox, belt, coupling
- Bearing
- Stator and rotor faults
- Internal electrical faults
- External electrical faults

## Process Faults

- High energy consumption
- Low efficiency
- Cavitation in pumps
- Flow turbulence in fans, blowers
- Filter and heat exchanger fouling
- Lubrication
- Oversize/undersize motors
- Air flow disturbance

## Power Monitoring

- $V_r$ ,  $V_s$  and  $V_t$
- $I_r$ ,  $I_s$  and  $I_t$
- Frequency
- Voltage Unbalance
- Current Unbalance
- Motor Load
- Power Factor
- Active Power
- Reactive Power
- Total and odd harmonics

# How Does It Work?

Artesis e-MCM uses a mathematical modelling technique to detect and diagnose faults in electric motors and connected equipment. The mathematical model, which consists of a set of differential equations representing the electromechanical properties of the system, is built up during the self-learning phase of operation. During this phase, the three input voltages and three output currents are continuously measured and processed using system identification algorithms which determine the model parameters under a full range of operating states. Once complete, Artesis e-MCM has a complete model representing normal behaviour of the machinery in a full range of operating states. When a fault starts to develop in the motor, drive train or the driven equipment, this has an effect on the output current waveform, making the real system behave differently from the model system. For example, small radial and torsional displacements resulting from an imbalance in a

driven fan are transmitted through the coupling to the motor, changing its electrical characteristics in a measurable and repeatable way. This allows Artesis e-MCM to use the motor as a sensor that can detect faults in the motor, drive train and the driven equipment. When monitoring, Artesis e-MCM continuously compares model parameters with those held in the reference model created during the self-training phase. By matching changes in each of these parameters against the equivalent physical characteristic of the motor or driven system and assessing the severity of the change, Artesis e-MCM determines whether the present condition of the equipment is normal, and if not what action should be taken. This approach not only allows much more sensitive and reliable alerting than is possible with conventional level-alarms, but also recognises the type of defect causing the problem.

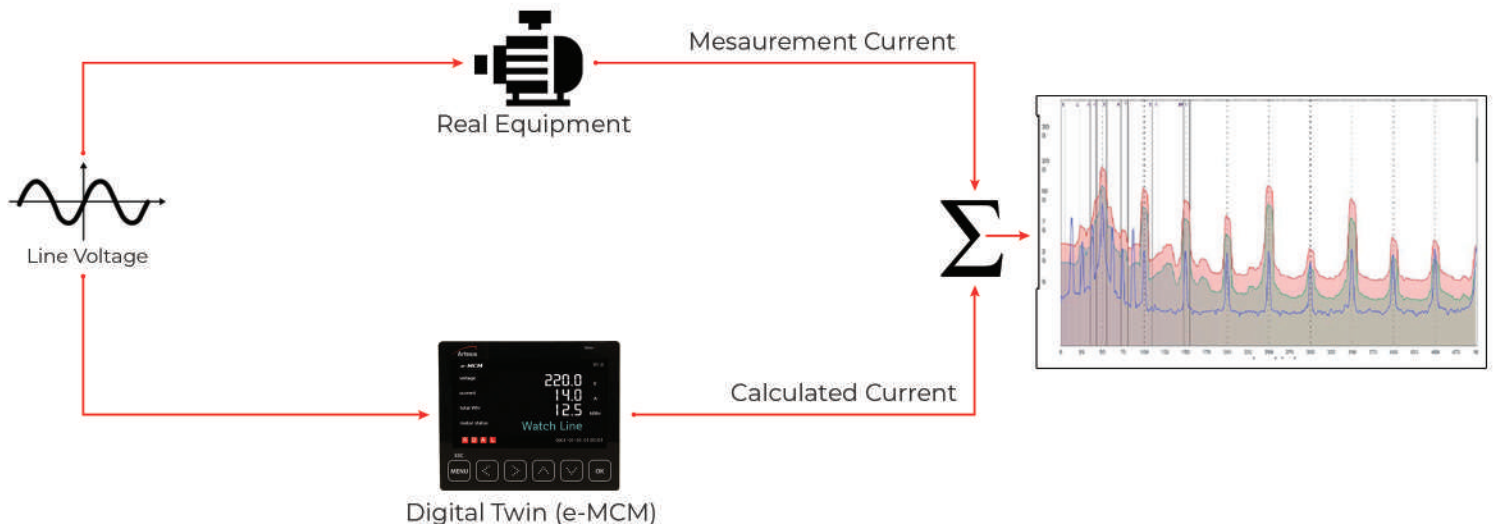

# It Simply Works

e-MCM provides clear information for fault detection, diagnostics, time to failure and corrective actions. It only demands your attention when it detects a problem. This makes it very attractive in comparison with walkaround systems which require considerable effort and cost just to find out whether you have a problem or not. It automatically assesses the severity of any variations from normal operation and presents the results of its sophisticated analysis to the user in a simple, compelling traffic light display. As a fault starts to progress, the traffic light changes from green to orange, indicating that maintenance action will be required in the future. A red traffic light indicates that the high severity of the problem requires immediate attention.

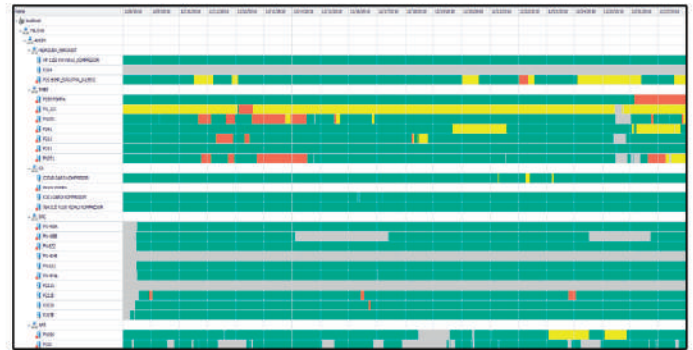
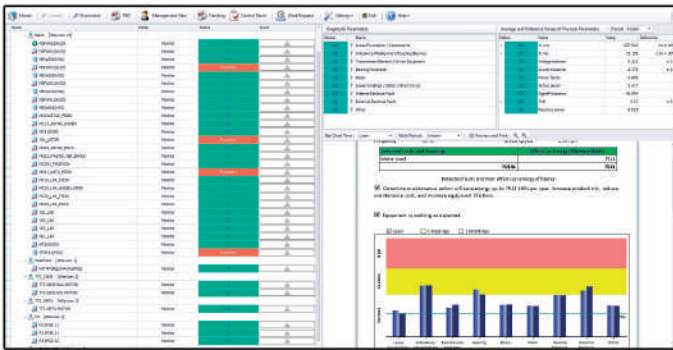

Artesis Enterprise Software

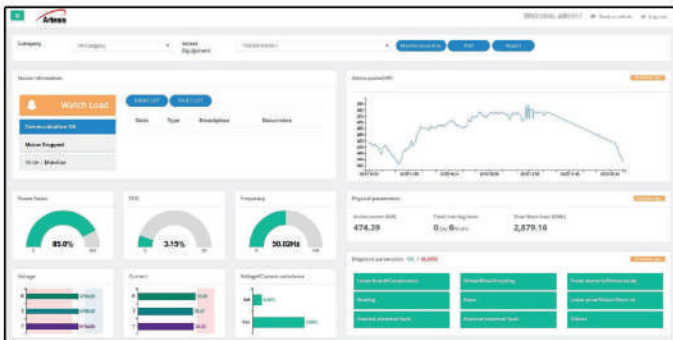

Artesis IoT Software

Permanently installed Software provides processed data results in an actionable form which greatly reduces the specialist diagnostic skills required of the user, making the benefits of condition monitoring available to many groups who have considered it too difficult in the past.

# Monitoring Software

e-MCM system offers various remote monitoring options ranging from local to cloud based IoT monitoring.

- AES Software (Windows based) running on local server
- Artesis Web IoT Platform on cloud server
- 3rd party monitoring software integration via OPC

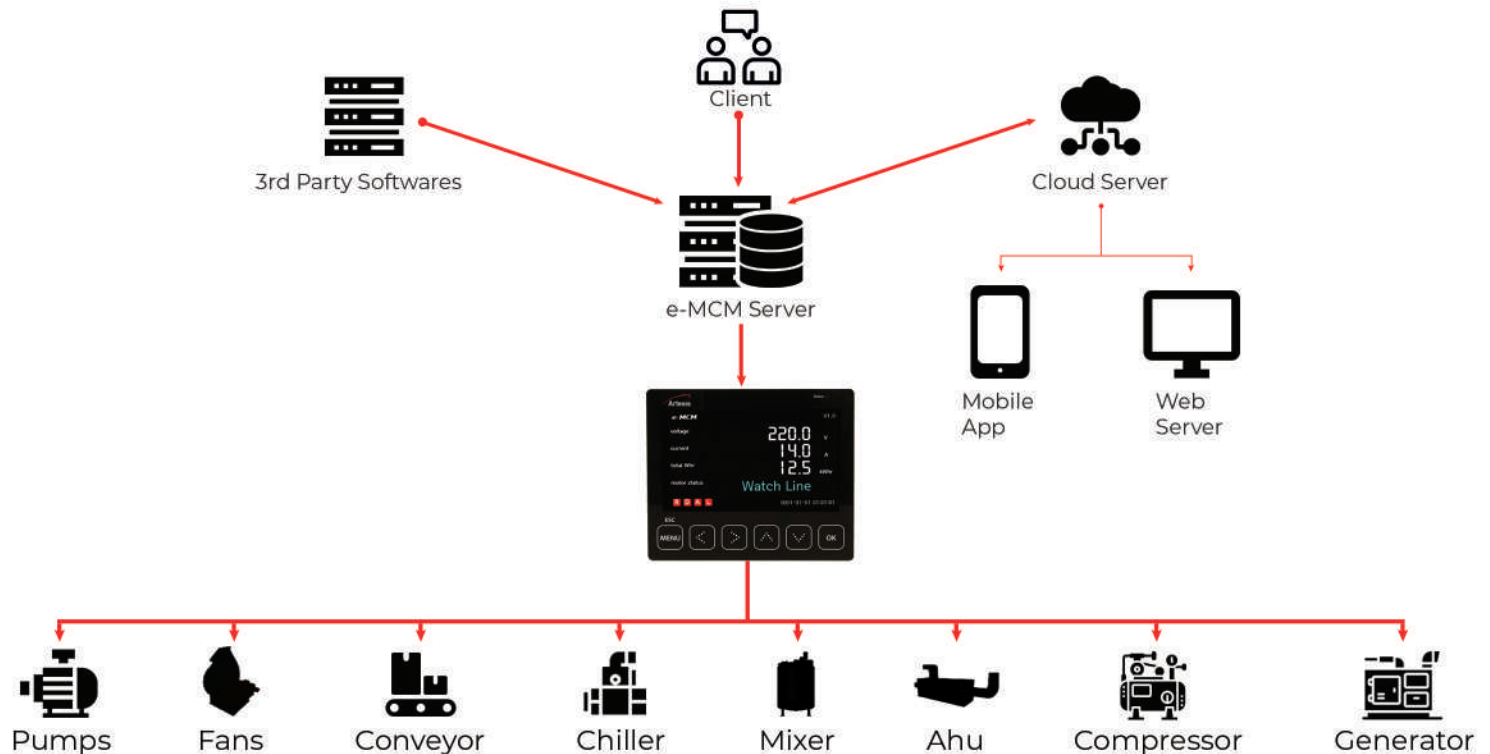

- Simple interface providing actionable information via automated fault diagnosis capability
- Comprehensive fault coverage by monitoring electrical, mechanical and process conditions of rotating equipment
- On remote or inaccessible equipment which is difficult to monitor with other technologies
- In hazardous or extreme environments where sensors cannot be mounted to the equipment
- Integration packages are available to a wide range of 3rd party systems, including Integrated Condition Monitoring, SCADA/HMI, and Reporting/Business Intelligence



# Advanced Fault Diagnosis and Alarm Types

Conventional condition monitoring systems are great at collecting data, but require a lot of expertise to turn it into actionable information – just the part you really need. Artesis e-MCM is able to use its knowledge of your machinery built up during the self-learning process not just to detect when a fault is developing but also to recognise the type of fault. This allows your maintenance team to focus their efforts in exactly right area, without relying on the presence of a diagnostics expert. The diagnostic system is able to identify most of the common mechanical faults associated with typical electric motor-driven equipment, from unbalance and misalignment to bearing problems. Additionally, since Artesis e-MCM works by measuring the current and voltage taken by the electric motor it can also diagnose problems with the electric motor, as well as giving an insight into the process conditions and the potential to optimise them on the basis of power, phase angle and total harmonic distortion.

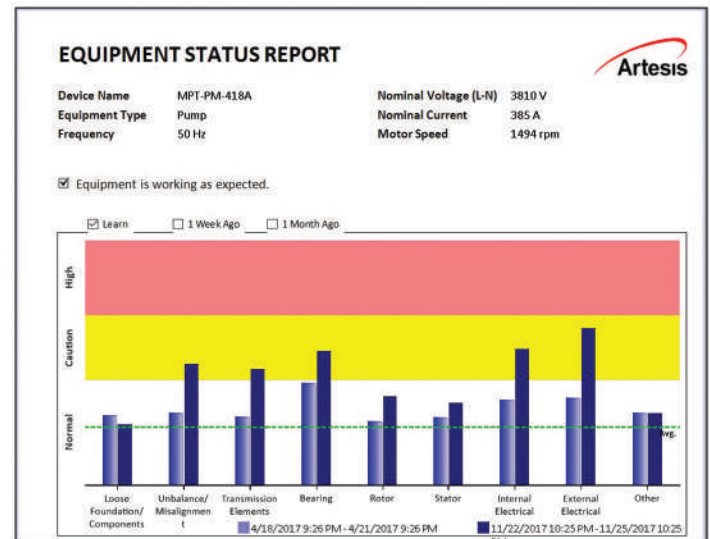
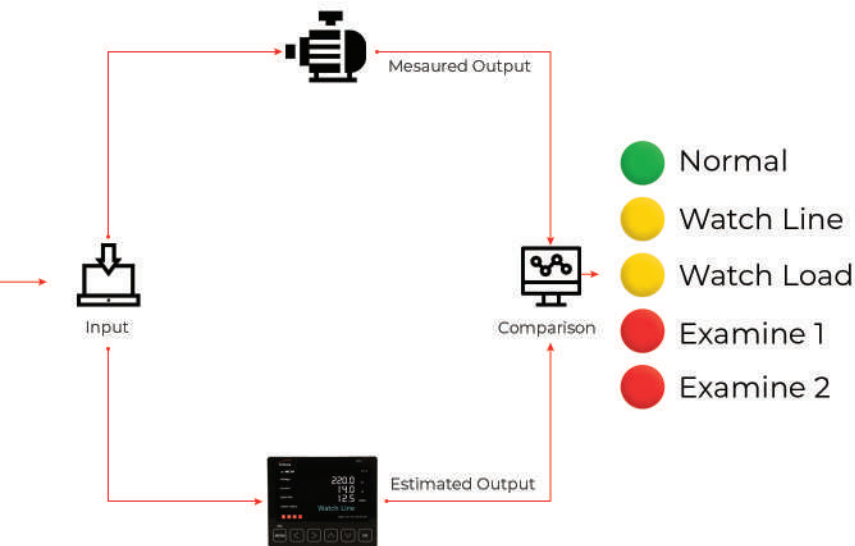

# Advanced Analysis Tools for Experts

The Artesis e-MCM software allows users detailed analysis with Power Spectral Density and Trend Analysis tools for root causes of the faults.

e-MCM is specifically designed to be self-sufficient, only requiring your intervention when it detects a problem. It can also act as an intelligent component of a complete, plant-wide monitoring and diagnosis system. You can connect it into your own systems using its standard interfaces, allowing results to be presented to your staff through existing display systems. Artesis can supply MCMScada software to collect and manage information from all your Artesis MCM units, provide enhanced diagnostic capability, and to allow remote operation of the complete system. This can also allow Artesis to help out with your condition monitoring program by providing remote advanced interpretation services.

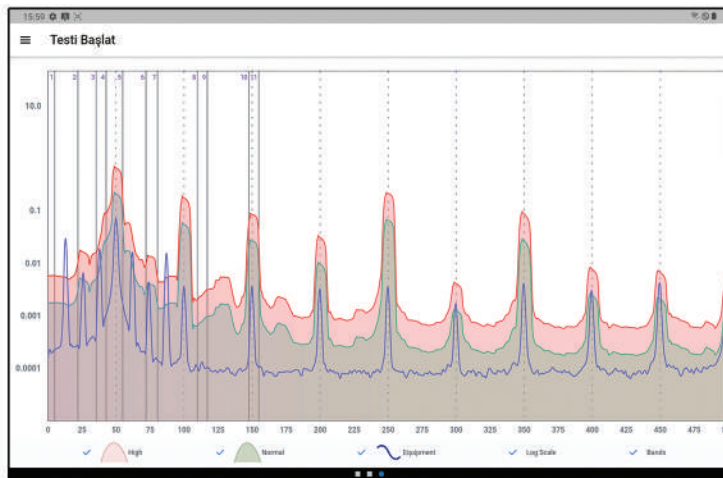

PSD Analysis Screen

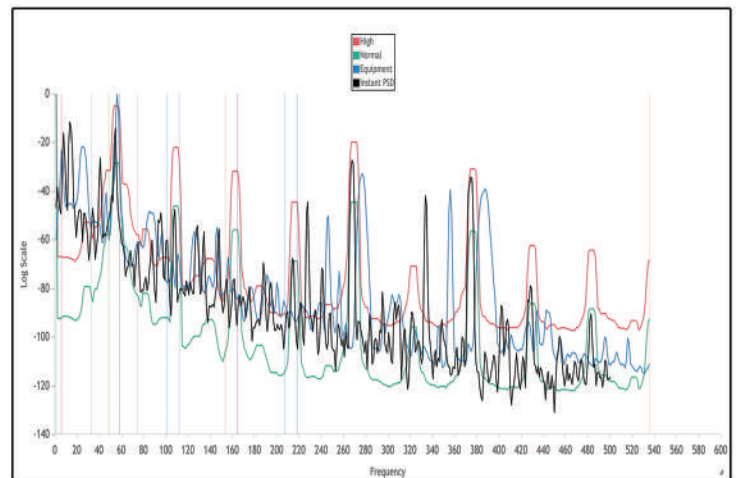

Trend Screen

- Multi language support
- Advanced trending tools
- Mail tool for diagnostic alerts
- OPC DA support
- Power spectral density analysis
- 6 channels waveform capture feature

# Only Viable Solution for Hard-to-Reach Equipment With Effortless Installation

---

Installing Artesis e-MCM is a simple matter of connecting it to the three supply phases of the motor using current (and sometimes voltage) transformers and mounting the monitor in any convenient panel. Artesis e-MCM is typically located in or near the motor control centre, making especially valuable in situations where the plant is not easily accessible, either because it is remote or because the local environment is hazardous or inhospitable. This approach gives you all the advantages of using online systems without the high cost of running cables to sensors mounted on the machine itself. When you first switch it on, e-MCM begins an automatic self-learning process during which it learns the normal operating condition of your equipment. At the end of this short training period it's ready to start monitoring, without forcing you to go through lengthy manual setups.



# Motor Condition Monitoring System e-MCM

No	Name	Function
1	Supply voltage terminal	Terminal for operational power (AC100~240V)
2	Empty terminal	No function
3	Motor voltage input	Terminal for motor input voltage
4	Status LED	Indicates Power status, Module status, etc.
5	CT connection port	Terminal for 3 phase CT connection (RJ11)
6	ZCT connection port	Terminal for ground CT connection
7	Reset button	Trip Relay Reset Button
8	RS-485 terminal	Terminal for RS-485 communication
9	Empty terminal	No function
10	HMI terminal	Terminal for connecting with HMI (RJ45)
11	Ethernet port	Terminal for ethernet communication (RJ45)

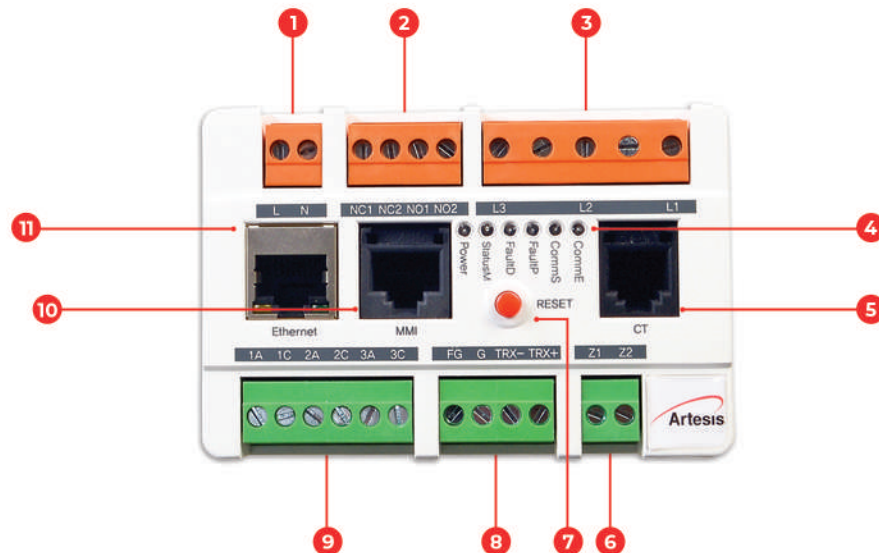

- Motor fault diagnosis + Power Monitoring
- Predictive diagnosis of Electrical and Mechanical Faults
- (3-phase AC motor) Energy meter function
- Measuring types THD, Current/ Voltage Unbalance, Active/Reactive Power
- Support Panel display monitor (4.3 "TFT LCD monitor)
- RS485 serial communication and Ethernet communication support
- EN 60255-26: 2013, EN 61010-1:2010, EN61326-1: 2006
- Compact size (94x63x100 mm)
- DIN rail and wall mount available

# e-MCM

## Communication Diagram

LAN Communication Diagram

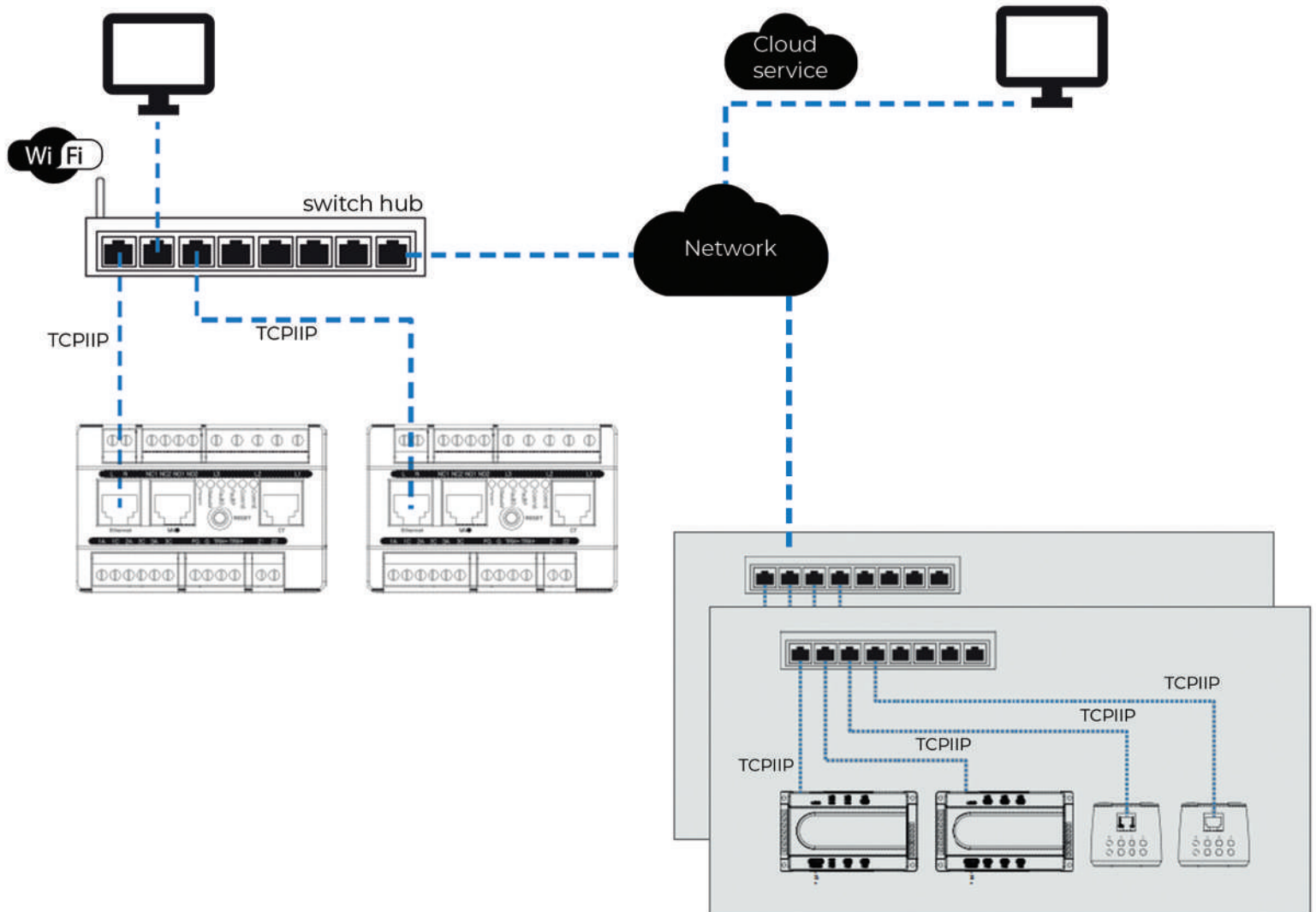

# e-MCM

## MV/HV Installation

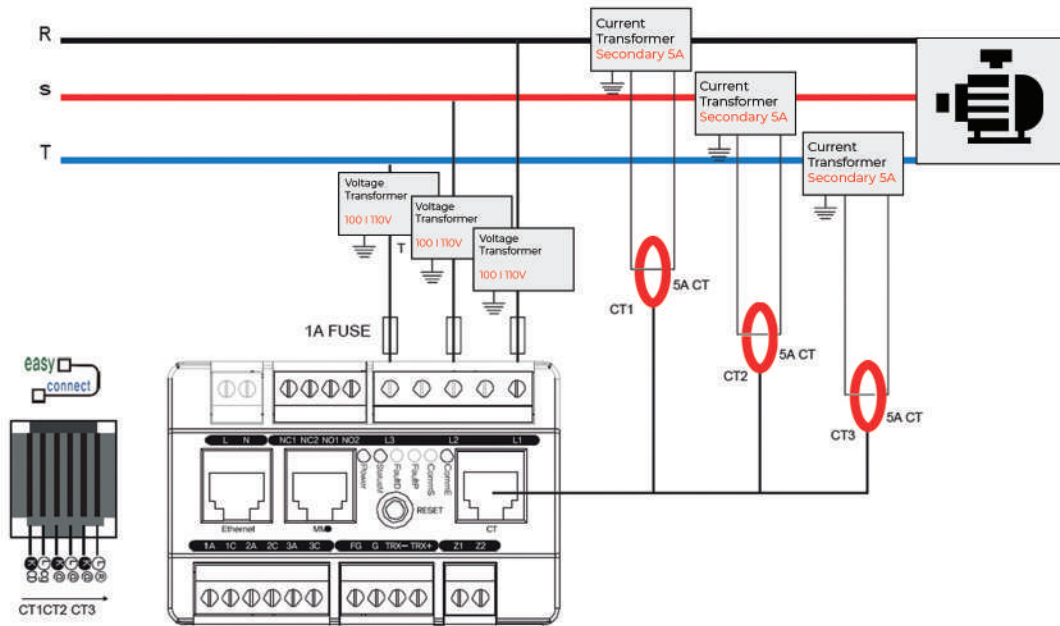

MV/HV - LINE Installation (3CT)  
Motor Voltage > 690V (L-L)

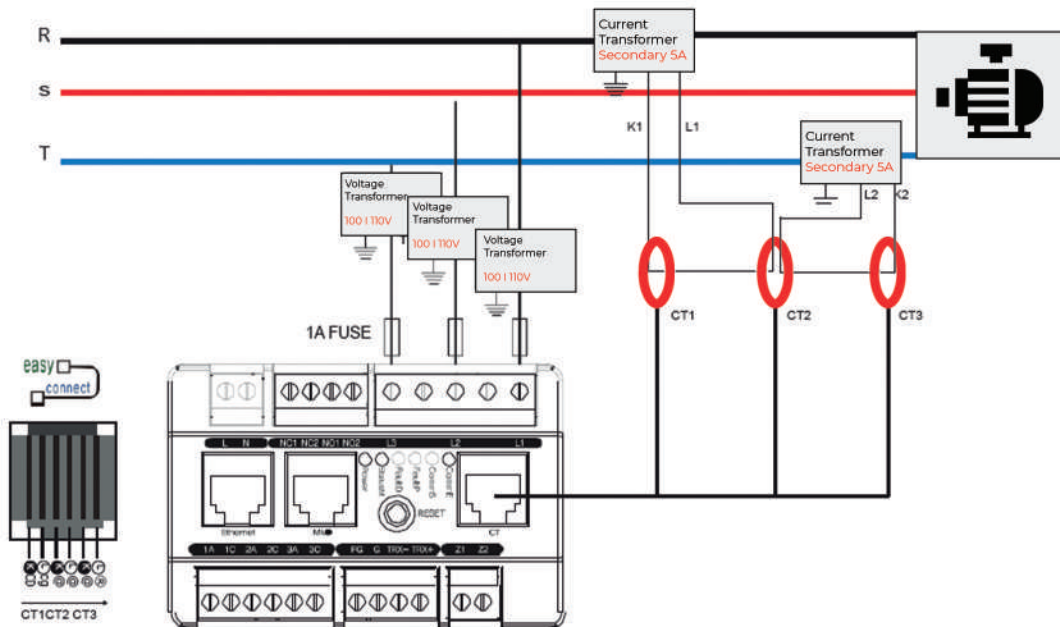

HV - LINE Installation (2CT)  
Motor Voltage > 690V (L-L)

# e-MCM

## LV Installation

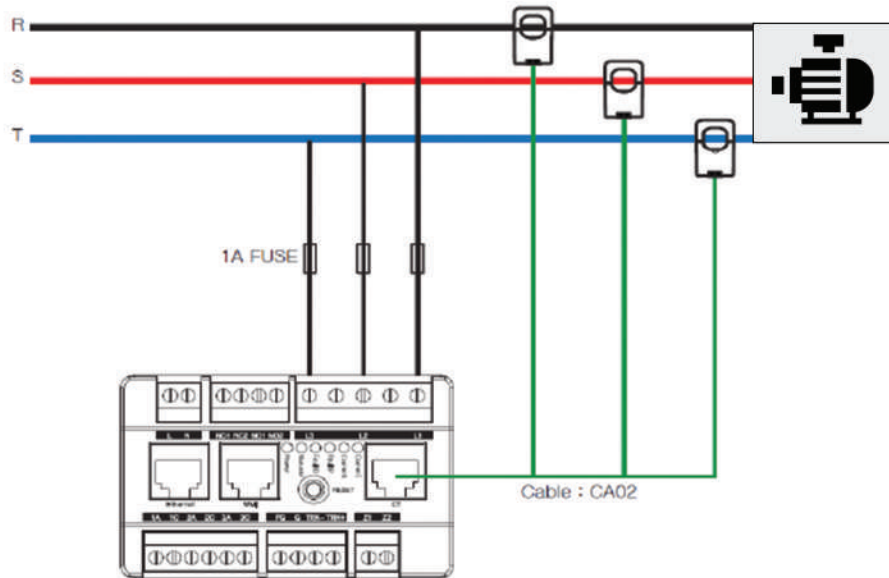

LV - LINE Installation Motor Voltage < 690V (L-L)  
 5A < Motor Current <2000A  
 CT:5A-2000A

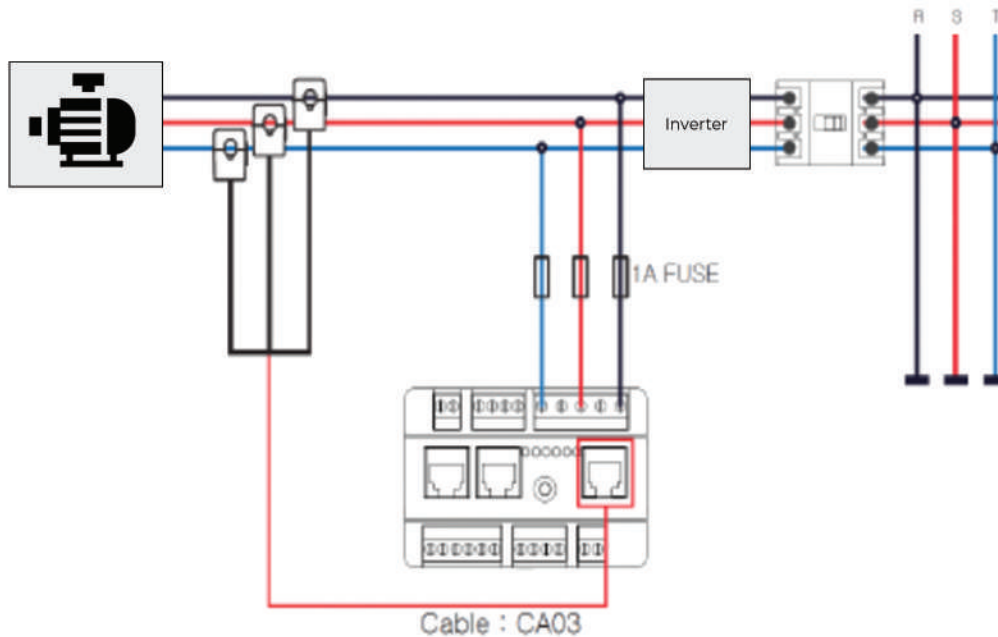

LV - Inv Installation Motor Voltage < 690V (L-L)  
 5A < Motor Current <2000A  
 CT:5A-2000A

# e-MCM Touch Panel Screen



Panel Display Monitor with 4.3" TFT LCD



- Used as field monitoring
- On-site power monitoring
- Clear display with 4.3" TFT LCD
- Plug and play with e-MCM device without external power supply
- Possible to change the setting of the device in the field
- Easy operation with large touch keys



## Terminal Description

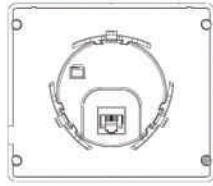

- LCD screen 4.3" TFT Color LCD
- Status LED Indication of operation status
- Six keys are used to select display and set
- Installation Clip The clips are used for fixing the HMI to the panel
- Communication terminal to e-MCM Device

## Dimensions

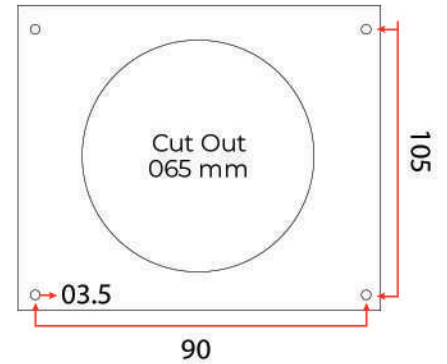
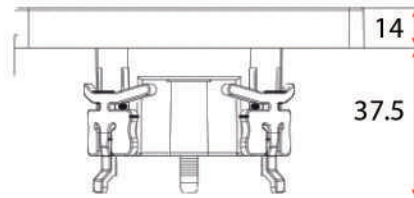
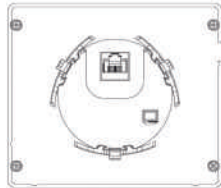

- **Step1**  
Panel Cutting

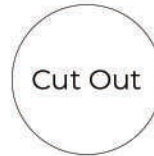

- **Step2**  
Put the HMI into the panel clip it

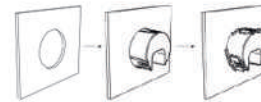

- **Step3**  
Connect with e-MCM

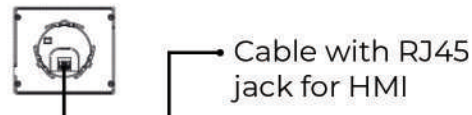

# e-MCM Datasheet

## Rated Specifications

<b>General Information</b>	
Motor Type	3-phase, AC motors & generator. Motor current (load) variation must be less than 45% during 6 sec data acquisition period. DOL, Star-Delta, Soft Starter, Variable Frequency Driver
<b>Ambient Conditions</b>	
Operating Temperature	-10 - 50 °C
Humidity	%80, Relative Humidity, non-condensing
Pollution Degree	2
Altitude	2000m (6562ft)
IP Rating	IP40
<b>Input Supply Voltage</b>	
Rated Voltage	100-240 Vac
Allowable Input Voltage	90% - 110% (of rated voltage)
Frequency	50/60Hz
Power Consumption	5W
Over Voltage Category	IEC61010 Cat III
<b>Measurement Voltage Inputs</b>	max 690Vac (Line to Line)
<b>Measurement Current Inputs</b>	Up to 2500A with three Cat III Current Transformers: 0.5% accuracy
<b>Frequency Range</b>	15-120Hz
<b>Communication</b>	
Network	RS485 Mosbus-RTU (Only for power monitoring)   TCP/IP Modbus TCP
<b>Display</b>	
4.3" LED	Displays electrical measurement, failure information, and setting values
Status LEDs	Displays power status, module status, comm status, alarm for diagnosis
Dimensions WxHxL	120 mm x 105 mm x 15 mm
<b>Physical</b>	
Weight	450 g (1 lb)
Dimensions WxHxL	96 mm x 64 mm x 110 mm
Mounting	Front Panel Mounting (indoor)
<b>Compliance &amp; Certifications</b>	
EMC	EMC Directive 2004/108/EC, EN61326-1, IEC61326-1
Safety	Electrical Safety Directive 2006/95/EC, EN61010-1, IEC61010-1

## Measurement Functions

Voltage	3 phase voltage (line-line), unbalance [%]
Current	3 phase current and leakage current, unbalance [%], THD [%]
Active Power	Measuring active power [kW]
Reactive Power	Measuring reactive power [kVAr]
Frequency	Measuring Frequency [Hz]
Power factor	Measuring Power factor
Energy	Total Whr, Today Whr, Prev day Whr
Data and Time	Year, month, day, hour, minute, second

## Auxiliary Functions

Password	Password Secure configuration
Communication	Serial/ethernet communication for monitoring status and event history
Total Running-Hour	Record of total running from installation which cannot be modified or cleared
Alarm	Output alarm signal to 3 output relays
Fault History	30(diagnosis) fault history to the flash memory
Limitation Of Auto Reset Attempt	Block auto-reset if the reset count exceeds the pre-set count within 30 minutes
Date/Time Information Setting	Save date/time to provide exact time of motor failure

## Motor Condition Monitor and Diagnostic Functions

<b>Status</b>	
OK	Motor and driven system is working as expected.
Watch Line	Watch Line is usually temporary in nature and generally the user does not need to take any action. However, it is recommended that when this status level occurs, the user should at least assess the extent of the change in the line conditions, as significant changes in the line voltages and currents may be dangerous to the motor. If the line status change is persistent, the user should assess the root cause of this change. For instance, it may be due to a problem in the contactors or for inverter driven motors the settings of the inverter may have been changed. In any case, if the root cause cannot be remedied easily and quickly and the new voltage supply condition presents no danger to the motor, the user has the option to send MCM to the UPDATE mode. This will allow MCM to learn the new voltage supply conditions, after which the status will eventually return to normal.
Watch Load	If the process load has not been altered deliberately, check for leakage, valve & vane adjustment, pressure gauge faults, manometer, dirty filters (fans, compressors). If the process is altered deliberately, device should be updated.
Examine 1	Plan Maintenance (First Level Alarm): There are developing mechanical and/or electrical fault(s).
Examine 2	Do Maintenance (Second Level Alarm): There are developing mechanical and/or electrical fault(s).

# Accessory-Split Core Current Transformers

<b>AC25R-10-100mA -E</b>	3x10A	Splitcore current transformers set, ( $\varnothing$ 25mm ) 10A:100mA
<b>AC25R-20-100mA -E</b>	3x20A	Splitcore current transformers set, ( $\varnothing$ 25mm ) 20A:100mA
<b>AC25R-30-100mA -E</b>	3x30A	Splitcore current transformers set, ( $\varnothing$ 25mm ) 30A:100mA
<b>AC25R-30-100mA -E</b>	3x60A	Splitcore current transformers set, ( $\varnothing$ 25mm ) 60A:100mA
<b>AC25R-100-100mA -E</b>	3x100A	Splitcore current transformers set, ( $\varnothing$ 25mm ) 100A:100mA
<b>AC25R-200-100mA -E</b>	3x200A	Splitcore current transformers set, ( $\varnothing$ 25mm ) 200A:100mA



<b>AC35R-300-100mA -E</b>	3x300A	Splitcore current transformers set, ( $\varnothing$ 35mm ) 300A:100mA
---------------------------	--------	---



<b>AC51R-400-100mA -E</b>	3x400A	Splitcore current transformers set, ( $\varnothing$ 51mm ) 400A:100mA
<b>AC51R-600-100mA -E</b>	3x600A	Splitcore current transformers set, ( $\varnothing$ 51mm ) 600A:100mA
<b>AC51R-800-100mA -E</b>	3x800A	Splitcore current transformers set, ( $\varnothing$ 51mm ) 800A:100mA



<b>AC80R-1000-100mA -E</b>	3x1000A	Splitcore current transformers set, ( $\varnothing$ 80mm ) 1000A:100mA
<b>AC80R-1500-100mA -E</b>	3x1500A	Splitcore current transformers set, ( $\varnothing$ 80mm ) 1500A:100mA



<b>AC105R-1200-100mA -E</b>	3x1200A	Splitcore current transformers set, ( $\varnothing$ 105mm ) 1200A:100mA
<b>AC105R-2000-100mA -E</b>	3x2000A	Splitcore current transformers set, ( $\varnothing$ 105mm ) 2000A:100mA





## EXCLUSIVE DISTRIBUTOR FOR INDIA

Address : R-375 TTC Industrial Area, Rabale, Navi Mumbai - 400 701

Contact : 022 - 2173 7777 / 022 - 4924 7777

Email : [sales@rokadegroup.com](mailto:sales@rokadegroup.com)

[www.rokadegroup.com](http://www.rokadegroup.com)

MUMBAI | PUNE | THANE | CHENNAI | DELHI | KOLKATA

